



Horizon Elite™

remote 1010, 1410 series Chewblet® ice machine

Features

Horizon Elite

- 1010 series - up to 978 lb (444 kg) in 24 hours
- 1410 series - up to 1372 lb (623 kg) in 24 hours
- automatically transport ice through a tube with RIDE® technology from up to 75' (22.8 m) away
- chewable, compressed nugget ice is preferred over cubes¹
- ice dispenses reliably from ice and beverage dispensers
- available with approximately 1.00" (2.54 cm) long standard Chewblet ice or optional 3/8" (0.95 cm) long Micro Chewblet™ ice
- quiet production without noisy harvest cycles

Revolutionary, scale inhibiting design

- produces ice that has 15% the TDS of the incoming water for optimum dispensing and long life in drinks
- quarantines and regularly expels scale producing dissolved solids to dramatically reduce scale buildup
- increases time between descaling and reduces or eliminates the need for expensive scale treatment
- saves 35% water compared to comparable cubers
- meets 2018 Department of Energy regulations
- three phase models ENERGY STAR® certified

Durable, attractive ice machine

- regular bearing inspection or replacement is not required
- upgraded, easy-to-read LED operating status and diagnostic display

Designed with sanitation in mind

- Agion® silver-based antimicrobial product protection of key ice and water contact components²
- floatless, sealed design inhibits formation of biofilms
- semi-automatic cleaning and sanitizing system

Warranty

- 3 years parts and labor, 5 years compressor parts

Certifications



¹ Independent third party studies. Contact Follett for details.

² Disclaimer: Antimicrobial protection is limited to the treated components and does not treat water or ice.

Short form specification:

Ice machine to be a Follett® Horizon Elite ice machine model _____ [Insert size/series, condenser type and installation/ mounting, from model number guide] capable of producing compressed nugget ice using an efficient, sanitary horizontal evaporator/ auger system and delivering ice by a flexible wire reinforced transport tube to
 ice storage bin, ice and water dispenser, ice and beverage dispenser, drop-in dispenser or Ice Manager™ diverter valve system, slide-out evaporator with utility docking station, front-mounted unit status display, evaporator water inlet at harvest end with automatic flush while producing ice, and semi-automatic cleaning and sanitizing system, plus all the features listed below and mounting/performance-enhancing accessories checked.

Model configurations					
For use with ¹	Install/mount	Condenser	V/Hz/Ph	Item number ⁵ 1010 series	Item number ⁵ 1410 series
ice storage bin	top mount	with	115/60/1 ⁴	HCD1010RBT	HCD1410RBT
		without	115/60/1	HCD1010NBT	HCD1410NBT
	RIDE	with	115/60/1 ⁴	HCD1010RBS	HCD1410RBS
		without	115/60/1	HCD1010NBS	HCD1410NBS
Follett Vision™ undercounter ice & beverage dispenser	RIDE	with	115/60/1 ⁴	HCD1010RVS	HCD1410RVS
		without	115/60/1	HCD1010NVS	HCD1410NVS
Cornelius PR150 undercounter ice & beverage dispenser ²	RIDE	with	115/60/1 ⁴	HCD1010RPS	HCD1410RPS
		without	115/60/1	HCD1010NPS	HCD1410NPS
countertop ice & beverage dispenser (by others)	top mount ³	with	115/60/1 ⁴	HCD1010RHT	HCD1410RHT
		without	115/60/1	HCD1010NHT	HCD1410NHT
	RIDE	with	115/60/1 ⁴	HCD1010RHS	HCD1410RHS
		without	115/60/1	HCD1010NHS	HCD1410NHS
drop-in dispenser (by others)	RIDE	with	115/60/1 ⁴	HCD1010RJS	HCD1410RJS
		without	115/60/1	HCD1010NJS	HCD1410NJS
Ice Manager diverter valve system	RIDE	with	115/60/1 ⁴	HCD1010RMS	HCD1410RMS
		without	115/60/1	HCD1010NMS	HCD1410NMS

¹ Ordered separately
² Not compatible with Micro Chewblet ice
³ Requires top kit (see page 5 for part number)
⁴ For three phase remote condensing unit, replace third character (D) with F
 e.g. HCF1010RBT
⁵ For Micro Chewblet ice, replace second character (C) with an M
 e.g. HMD1010RBT

Job _____

Item _____

Accessories

- Top kit for ice and beverage dispensers (page 5)
- Water filters (refer to form# 9905)
- Wall mount bracket (item# 00997098)
- Ice machine stand, height-adjustable (item# 00997080)
- Timer to control one or two ice machines (item# 00967625)
- Longer ice transport tube, specify length: ___ ft/m in 5'/1.5 m increments (10'/3 m provided as standard for RIDE models) (item# 00174896)
- Insulated refrigeration lines (not pre-charged) for 1010R and 1410R
 - 35' (11 m) (item# 00193227)
 - 50' (50 m) (Item# 01262328)
- SafeCLEAN Plus™ ice machine cleaner
 - 1 x 8 oz (237 ml) bottle (item# 01147826)
 - 6 x 8 oz (237 ml) bottles (item# 01149954)
 - Carton of 24 x 8 oz (237 ml) bottles (item# 01149962)
- SaniSponge™, 24 sanitary sponges (item# 01075431)

Dimensional drawing

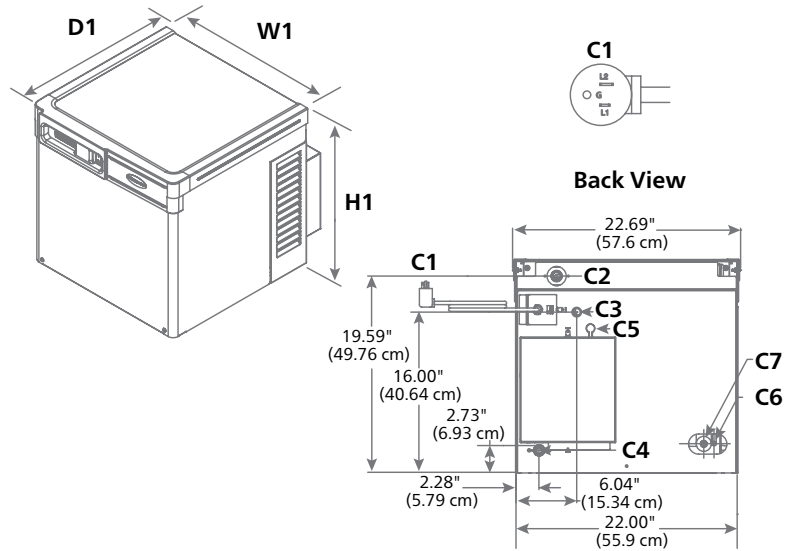

Specification, evaporator unit

	Horizon Elite 1010 series	Horizon Elite 1410 series
W1 Width	22.70" (57.7 cm) Fits on 22.00" wide dispensers	22.70" (57.7 cm) Fits on 22.00" wide dispensers
D1 Depth	22.50" (57.1 cm)	24.50" (62.2 cm)
H1 Height	21.25" (53.9 cm)	21.25" (53.9 cm)
Clearance	top, left and right – 1.00" (2.54 cm)	top, left and right – 1.00" (2.54 cm)
C1 Electrical 115 V/60/1	5 amps, requires dedicated 15 amp circuit, 6' (1.8 m) cord, NEMA 5-15 plug	5 amps, requires dedicated 15 amp circuit, 6' (1.8 m) cord, NEMA 5-15 plug
Operating power	0.6 kW	0.6 kW
C2 Ice transport tube	see page 7 for details	see page 7 for details
C3 Water inlet	3/8" OD push-in water inlet – internal connection	3/8" OD push-in water inlet – internal connection
C4 Drain	3/4" MPT, 1" drain required see page 6 for details	3/4" MPT, 1" drain required see page 6 for details
C5 Ice bin signal cord	for Vision applications only	for Vision applications only
C6 Liquid line	3/8"	3/8"
C7 Suction line	5/8"	5/8"
Air temperature	50 -100 F (10 - 38 C)	50 -100 F (10 - 38 C)
Water temperature	45 - 90 F (7 - 32 C)	45 - 90 F (7 - 32 C)
Potable water pressure	10 - 70 psi (69 - 483 kPa)	10 - 70 psi (69 - 483 kPa)
Ice production	see ice production chart on page 8	see ice production chart on page 8
Energy consumption 90 F (32 C) air, 70 F (21 C) water	single phase – 4.68 kWh three phase – 3.57 kWh per 100 lb (45.4 kg) ice	single phase – 4.63 kWh three phase – 3.34 kWh per 100 lb (45.4 kg) ice
Water consumption	12.0 gal (47 L) of potable water per 100 lb (45.4 kg) of ice (per AHRI test standards). 12.4 gal (46.9 L) at low TDS flush setting	12.5 gal (47 L) of potable water per 100 lb (45.4 kg) of ice (per AHRI test standards). 12.3 gal (46.5 L) at low TDS flush setting
Refrigerant	R404a	R404a
BTU/hr (Kcal/hr) at 0 F (-18 C) evaporator, 90 F (32 C) ambient air	7,700 (1,940)	10,000 (2,520)
Rack systems EPR valve - set to EPR valve to be supplied by installer	0 F (-18 C)	0 F (-18 C)
Approximate ship weight	195 lb (88 kg)	205 lb (93 kg)
Approximate net weight	185 lb (84 kg)	195 lb (88 kg)
NOTE: For indoor use only. Outdoor installation of low side is not recommended and will void warranty.		

Dimensional drawing

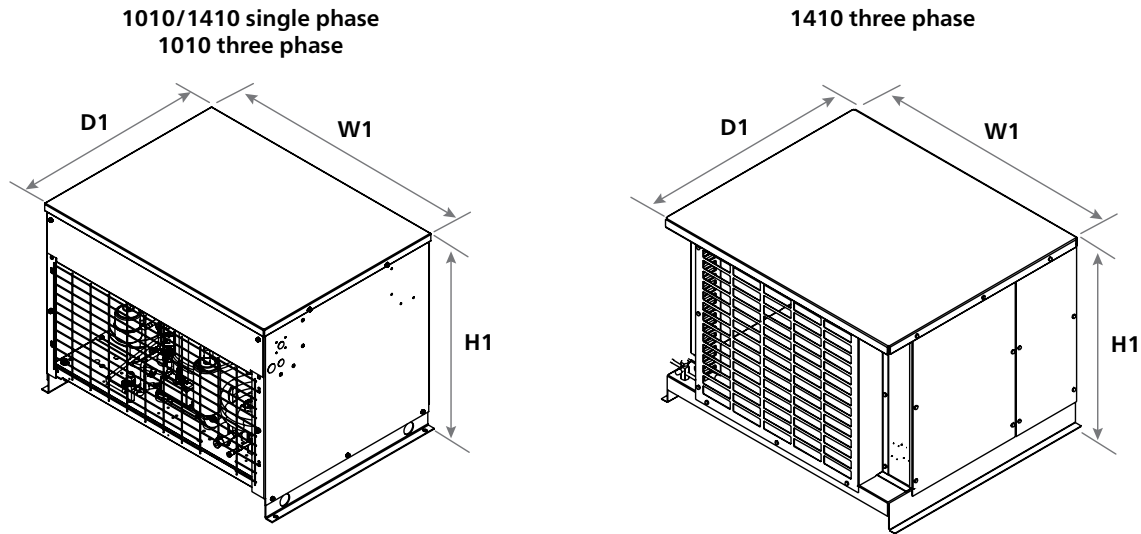

Specification, condenser unit

	Horizon Elite 1010 series	Horizon Elite 1410 series
W1 Width	36.25" (91.4 cm) – all models	36.25" (90.1 cm) – single phase 37.75" (95.9 cm) – three phase
D1 Depth	25.50" (64.8 cm) – all models	25.50" (64.8 cm) – single phase 28.25" (71.6 cm) – three phase
H1 Height	26.10" (66.3 cm) – all models	26.10" (66.3 cm) – single phase 19.75" (50.2 cm) – three phase
Electrical	single phase – 208-230/60/1 three phase – 208-230/60/3	single phase – 208-230/60/1 three phase – 208-230/60/3
Operating power	single phase – 2.4 kW three phase – 2.2 kW	single phase – 4.2 kW three phase – 3.0 kW
Minimum circuit ampacity	single phase – 10.7 A three phase – 9.9 A	single phase – 19.3 A three phase – 15 A
Maximum overcurrent protection	single phase – 15 A three phase – 15 A	single phase – 30 A three phase – 15 A
Outdoor condensing unit operating limits (air temperature)	min -20 F (-29 C) max 120 F (49 C)	min -20 F (-29 C) max 120 F (49 C)
Maximum refrigerant line run length	100' (30.5 m)	100' (30.5 m)
Maximum line rise above evaporator	35' (10.7 m)	35' (10.7 m)
Evaporator mounting above condenser	15' (4.6 m)	15' (4.6 m)
Maximum refrigeration line drop without oil trap	15' (4.6 m)	15' (4.6 m)
Refrigerant charge	12.5 lb required at installation	12.5 lb – single phase 8.5 lb – three phase required at installation
Approximate ship weight	260 lb (118 kg)	270 lb (122 kg) – single phase 230 lb (104 kg) – three phase
Approximate net weight	250 lb (114 kg)	260 lb (118 kg) – single phase 210 lb (95 kg) – three phase

NOTE:

1. The entire liquid line should be insulated separately from the suction line.

1 – Locating the ice machine

Horizon Elite remote Chewblet ice machines allow top-mounting or mounting in a base cabinet, on a wall or on a floor stand up to 75' (22.8 m) from the dispenser or ice bin with RIDE technology. In-cabinet mounting (RIDE applications) require special attention to service access, unit ventilation and ice tube runs (see pages 5-7).

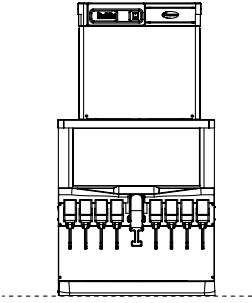
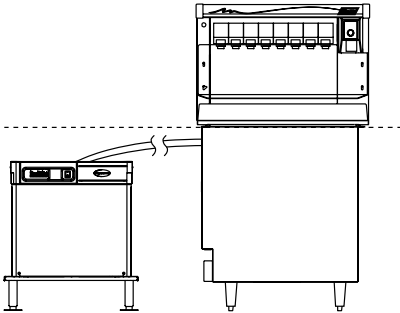
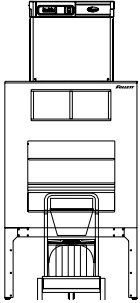
Top mounting – ice and beverage dispensers (by others)	RIDE model – Follett low-profile Vision and Cornelius PR150 ice and beverage dispensers	Top mount on Follett ice storage bins
		
<p>Important specifier notes</p> <ol style="list-style-type: none"> 1. Dispenser must be compatible with nugget ice. See page 5 for compatible ice and beverage dispenser models and top kit numbers. 2. Verify ceiling or soffit height to ensure sufficient top clearance. 	<p>Important specifier notes</p> <ol style="list-style-type: none"> 1. See page 5 for critical clearance requirements. 2. Ice transport tube ships with Vision ice and beverage dispenser (Vision applications only). 3. Ice transport tube ships with Horizon Elite ice machine for Cornelius dispensers. 	<p>Important specifier notes</p> <ol style="list-style-type: none"> 1. See form# B300 for bin sizing. 2. Verify ceiling or soffit height to ensure top clearance. 3. Locate floor sink or grate and drains in front of storage bin. 4. Do not position bin drain lines to block Ice•Devil™ bin cart.

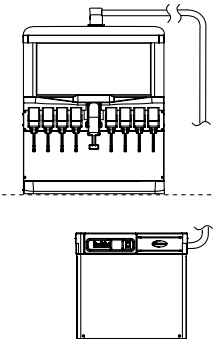
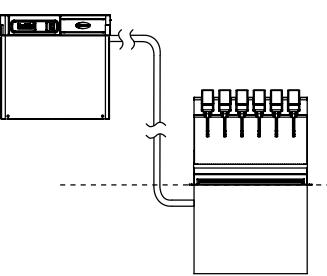
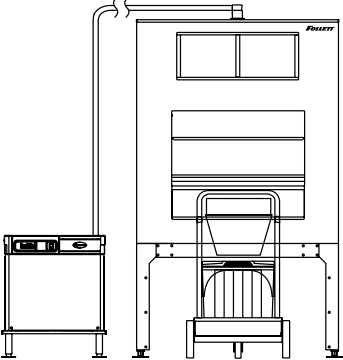
RIDE model – ice and beverage dispensers (by others)	RIDE model – drop-in beverage dispensers (by others)	RIDE model – Follett ice storage bins
		
<p>Important specifier notes</p> <ol style="list-style-type: none"> 1. Dispenser must be compatible with nugget ice. Compatible dispensers include Cornelius DB/ED/DF150/175, Lancer 4500-22N, FS-16N and FS-44N, Servend MD150/175/200/250 SV150/175/200/250 and Follett Symphony Plus™ 110CM, as well as dispensers listed on page 5. 2. Top kit MSF30SC required with Coca-Cola Freestyle 7000. Top adapter 46412 and ice kit 46430 must also be ordered from Coca-Cola. Top kit HSF26SC required with Coca-Cola Freestyle 9100. Consult with Coca-Cola and Follett to qualify application prior to ordering. 3. RIDE application is approved only for Pepsi Spire 3.0, 5.0 and 4.1 designed for top mount ice machines and requires MSP24SC for 3.0 and MSP30SC for 5.0 and 4.1, ordered separately. For manual fill versions of Pepsi Spire 3.0, 5.0 and 4.1, contact factory. 4. See page 5-6 for critical clearance requirements. 	<p>Important specifier notes</p> <ol style="list-style-type: none"> 1. Compatible with the following dispensers: Cornelius 1522, 1722, 2323 and Lancer 2200, 2300, 23300. 2. Requires 12.00" (30.5 cm) of access space for installation on transport tube side. 3. See page 5-6 for critical clearance requirements. 	<p>Important specifier notes</p> <ol style="list-style-type: none"> 1. See form# B300 for bin sizing. 2. Locate floor sink or grate and drains in front of storage bin. 3. Do not position bin drain lines to block Ice•Devil bin cart.

1 – Locating the ice machine (continued)

Top mounting – compatible ice and beverage dispensers ¹					
Manufacturer	Model Number	Width in (cm)	Depth ² in (cm)	Height ³ in (cm)	Top kit
Coca-Cola dispensers	Freestyle 7000	30.10 (76.5)	33.11 (79.0)	47.00 (119.4)	H22F30-F ^{4,5}
	Freestyle 9000	25.50 (64.8)	35.50 (90.2)	73.75 (187.3)	H22F24-F ^{4,6}
	Freestyle 9100	25.50 (64.8)	39.25 (99.7)	77.25 (196.2)	H22F26-F ⁴
Cornelius dispensers	DB/ED/DF 200 series	30.00 (76.2)	30.00 (76.2)	34.38 (87.3)	H22C30-F
	DB/ED/DF 250 series	30.00 (76.2)	30.00 (76.2)	38.38 (97.5)	H22C30-F
	DB/ED/DF 300 series	44.00 (111.8)	30.00 (76.2)	34.00 (86.4)	H22C44-(F or B) ⁷
	FlavorFusion/Overload	30.00 (76.2)	30.70 (78.0)	39.38 (100.0)	H22C30-F-FF
	IDC215	30.00 (76.2)	30.70 (78.0)	39.38 (100.0)	H22C30-F-IDC
	IDC255 and Pro Fast Gate	30.00 (76.2)	30.70 (78.0)	36.38 (92.4)	H22C30-F-IDC ⁸
Lancer dispensers	4500-30N	30.00 (76.2)	30.50 (77.5)	36.50 (92.7)	H22L30-(F or B) ⁷
	FS-22N	22.00 (55.9)	30.50 (77.5)	42.13 (107.0)	H22L22-F
	FS-30N	30.00 (76.2)	30.50 (77.5)	42.13 (107.0)	H22L30-(F or B) ⁷
	Bevariety	30.00 (76.2)	31.00 (78.7)	37.75 (95.9)	H22L30-F-STP
	Sensation 30"	30.00 (76.2)	31.00 (78.7)	38.25 (97.2)	H22L30-F-STP
	Sensation 44"	44.00 (111.8)	31.00 (78.7)	39.38 (100.0)	H22L44-F-STP
	Touchpoint	32.50 (82.55)	33.70 (85.6)	40.00 (101.6)	H22L30-F-STP
Pepsi dispensers	Spire 3.0	27.00 (68.6)	35.00 (88.9)	38.12 (96.8)	H22P24-F
	Spire 5.0 / 4.1	30.50 (77.5)	36.00 (91.4)	42.75 (108.6)	H22P30-F
Servend dispensers	MDH-302	42.75 (108.6)	31.00 (78.7)	32.38 (82.2)	H22S44-(F or B) ⁷
	MDH-402	60.00 (152.4)	30.50 (77.5)	32.38 (82.2)	H22S60-(F or B) ^{7,9}

¹ All approved dispensers can be filled with a RIDE model Horizon Elite ice machine without a top kit except for Coca-Cola Freestyle 7000 and Pepsi Spire 3.0, 5.0 and 4.1, see page 4 for details.

² Requires minimum 0.50" (1.27 cm) clearance between back of dispenser and wall.

³ Net height after installation of top kit (excluding height of ice machine).

⁴ Consult with Coca-Cola and Follett to qualify application prior to ordering.

⁵ Top adapter 46412 and ice kit 46430 must also be ordered from Coca-Cola.

⁶ Adapter must also be ordered from Coca-Cola. KO IC Code: 46010 (Silver), 46011 (Red) or 46012 (Black).

⁷ Specify "F" for front facing, or "B" for backward facing units.

⁸ Contact factory regarding IDC Pro.

⁹ 60-inch models: Please specify number of Horizon Elite ice machines and location. D = 2; R = 1 on right side; L = 1 on left side.

2 – Undercounter/in-cabinet mounting

Cabinet details	
<p>Important specifier notes</p> <ol style="list-style-type: none"> 1. Cabinet door opening must meet minimum size requirements shown and be free of obstructions to allow ice machine to slide out (no lip or utilities to block removal). 2. Cabinet base must be capable of supporting ice machine and allow ice machine to rest flat on cabinet bottom. 3. No counter supports, electric or plumbing can run in front of the ice machine. 	

3 – Horizon Elite ice machine mounting accessories

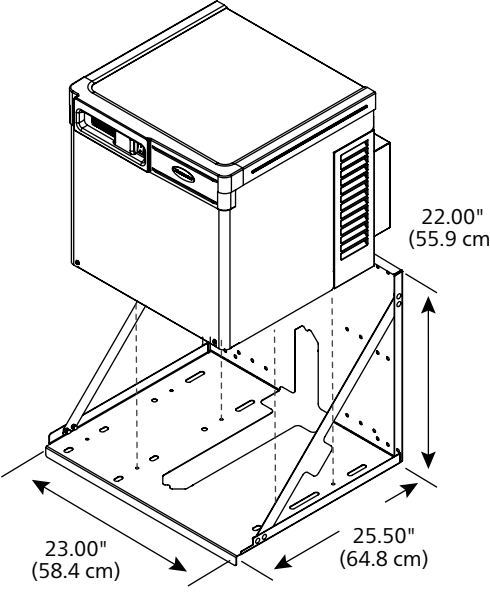
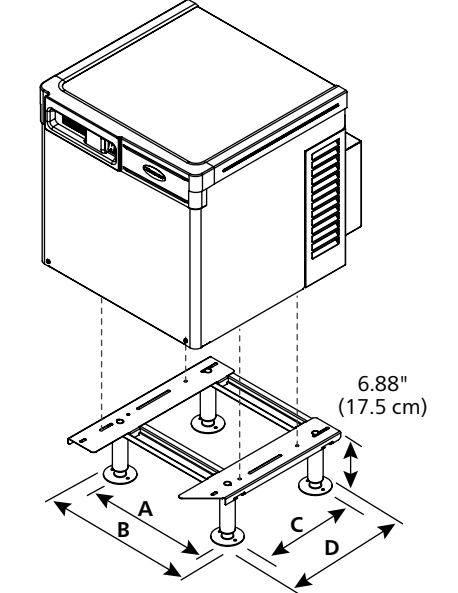
Optional wall mount bracket	Optional machine stand	Important specifier notes
 <p>23.00" (58.4 cm)</p> <p>25.50" (64.8 cm)</p> <p>22.00" (55.9 cm)</p>	 <p>6.88" (17.5 cm)</p> <p>A - 15.875" (40.3 cm) C - 13.00" (33.0 cm) B - 19.375" (49.2 cm) D - 21.00" (53.3 cm)</p>	<ol style="list-style-type: none"> For secure wall mounting, specify optional wall mount bracket. Wall and fasteners must support the weight of the ice machine, bracket, supply water and ice. Use of a backing board may be required with hollow wall construction. Machine stand mounting adds 6.88" (17.5 cm) to height of ice machine. No dips in tube routing allowed. Ice transport tube needs minimum 1/4" per foot (2 cm per meter) pitch toward ice machine and should be secured to prevent dips and traps from forming.

4 – Horizon Elite drain - specifier guidelines

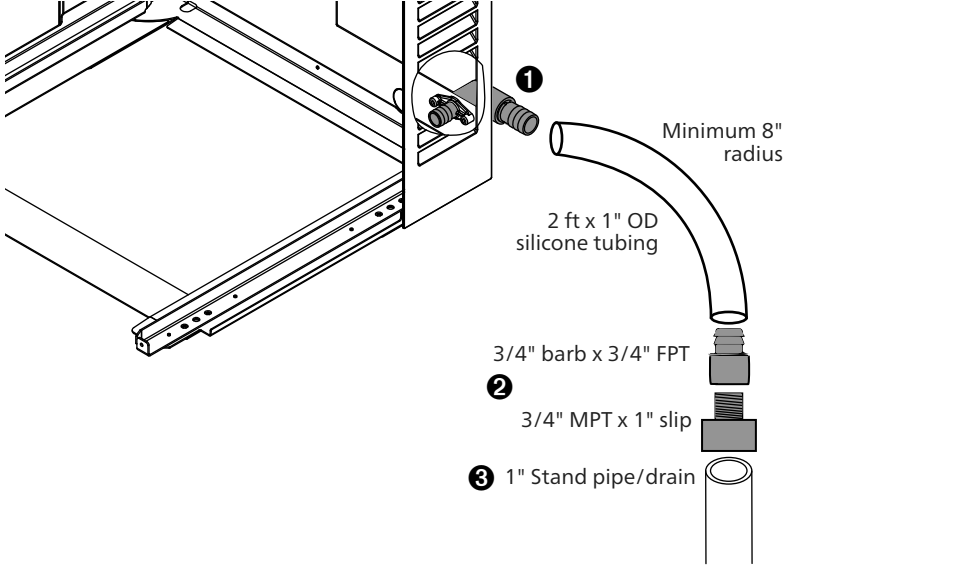
Drain details	Important specifier notes: Where code allows, follow recommendation below.
 <p>Minimum 8" radius</p> <p>2 ft x 1" OD silicone tubing</p> <p>3/4" barb x 3/4" FPT</p> <p>3/4" MPT x 1" slip</p> <p>1" Stand pipe/drain</p>	<ol style="list-style-type: none"> Connect the silicone tubing to the ice machine 3/4" drain barb ①. Assemble the 3/4" barb x 3/4" FPT to the 3/4" MPT x 1" slip. Connect the other end of the silicone tubing to the 3/4" barb ②. Connect the 1" slip fitting to the 1" stand pipe/drain ③. <p>Note: Minimum 8" radius on silicone drain line. Drain line from the ice machine must have at least 1/4" per foot pitch (6.4 mm/0.3 m).</p> <p>Note: Stand pipe/drain provided by others. All other components provided with ice machine.</p>

5 – Horizon Elite ice tube runs - specifier guidelines

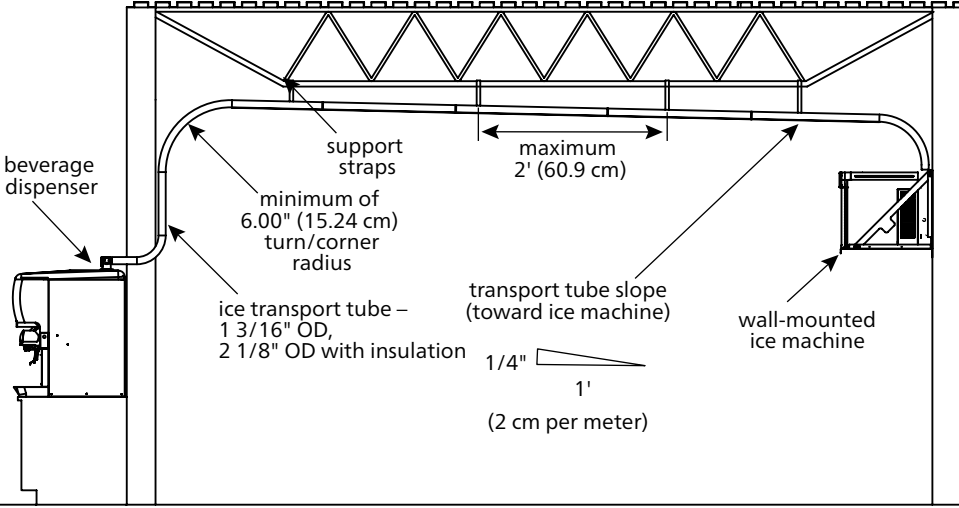
Long tube runs for RIDE remote ice delivery equipment	Important specifier notes
 <p>Diagram illustrating the installation of long tube runs for RIDE remote ice delivery equipment. The setup shows a beverage dispenser on the left and a wall-mounted ice machine on the right. The ice transport tube is supported by straps and has a minimum 6.00" (15.24 cm) turn/corner radius. The tube is insulated and has a 1 3/16" OD, 2 1/8" OD with insulation. The tube slope is 1/4" per 1' (2 cm per meter) towards the ice machine. The maximum run length between supports is 2' (60.9 cm).</p>	<p>Important specifier notes</p> <ol style="list-style-type: none"> 75' (22.8 m) maximum ice transport tube run. Tubing routing bends must have a 6.00" (15.24 cm) radius or larger. Dips and traps are not allowed. If not supported from underneath, secure insulated ice transport tube at least every 2' (60.9 cm) to prevent drips and traps. Relative humidity levels above 80% in areas where the ice machine or ice transport tube is located may produce excessive condensation that will cause water damage. Contact factory for recommendations on running tubing through a decorative soffit or chase.

Remote condensing unit

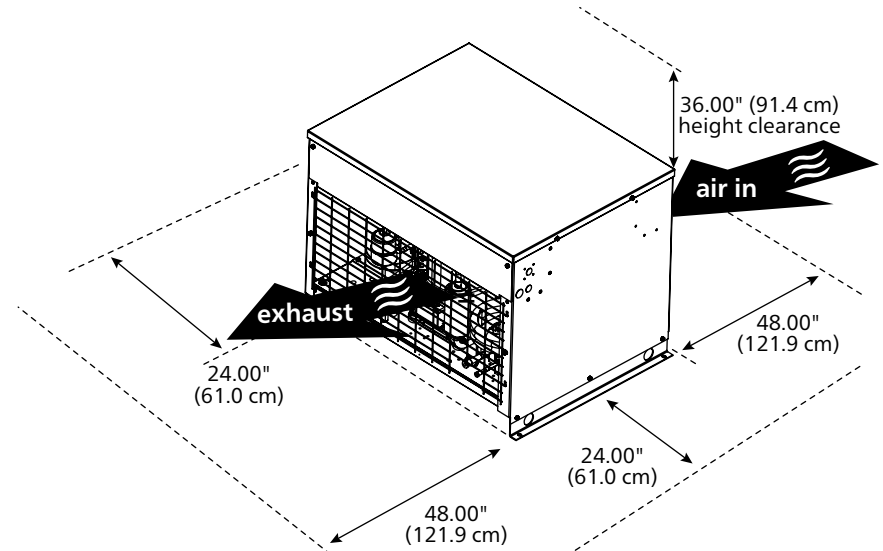
Condensing unit installation specifications	
<p>Important specifier notes</p> <ol style="list-style-type: none"> Provide front, back, top and side clearances as shown. The maximum refrigerant line run length is 100' (30.5 m). Installations require 12.5 lb for 1010/1410 single phase and 1010 three phase and 8.5 lb for 1410 three phase. The maximum line rise above the evaporator is 35' (10.7 m). Condensing unit above evaporator unit – 35' (10.7 m) (installations with rise over 20' (6.1 m) require additional suction line s-trap at midpoint rise). The evaporator can only be mounted a maximum of 15' (4.6 m) above the condensing unit. <p>Note: The service loop is not included when calculating length, rise or drop in the tubing run.</p>	 <p>Diagram illustrating the condensing unit installation specifications. The unit is shown with dimensions: 48.00" (121.9 cm) width, 24.00" (61.0 cm) depth, and 36.00" (91.4 cm) height clearance. The unit is labeled with "air in" and "exhaust".</p>

Note: To connect evaporator/ice machine to rack systems, see page 3.

Ice production – Horizon Elite 1010 series, air-cooled

Inlet water temperature F (C)	Ambient air temperature F (C)					lb (kg) production in 24 hr
	60 (16)	70 (21)	80 (27)	90 (32)	100 (38)	
50 F (10 C)	1051 (477)	978 (444)	906 (411)	834 (379)	763 (346)	
60 F (16 C)	1037 (471)	925 (420)	855 (388)	796 (361)	737 (335)	
70 F (21 C)	937 (425)	871 (395)	805 (366)	758 (344)	711 (323)	
80 F (27 C)	904 (410)	839 (381)	774 (351)	727 (330)	680 (309)	
90 F (32 C)	872 (396)	807 (366)	743 (337)	696 (316)	648 (294)	

Ice production – Horizon Elite 1410 series, air-cooled

Inlet water temperature F (C)	Ambient air temperature F (C)					lb (kg) production in 24 hr
	60 (16)	70 (21)	80 (27)	90 (32)	100 (38)	
50 F (10 C)	1474 (669)	1372 (623)	1269 (576)	1212 (550)	1154 (524)	
60 F (16 C)	1385 (628)	1292 (586)	1198 (544)	1148 (521)	1097 (498)	
70 F (21 C)	1296 (588)	1212 (550)	1127 (511)	1083 (492)	1039 (472)	
80 F (27 C)	1239 (562)	1155 (524)	1072 (487)	1030 (468)	988 (449)	
90 F (32 C)	1181 (536)	1099 (499)	1017 (462)	976 (443)	936 (425)	



ENERGY STAR and the ENERGY STAR mark are registered trademarks owned by the U.S. Environmental Protection Agency.
Agion is a registered trademark of Sciessent LLC.

HORIZON ELITE, ICE•DEVICE, ICE MANAGER, MICRO CHEWBLET, SAFECLEAN PLUS, SANISPONGE, SYMPHONY PLUS and VISION are trademarks of Follett LLC.
CHEWBLET, FOLLETT and RIDE are registered trademarks of Follett LLC, registered in the US.

Follett reserves the right to change specifications at any time without obligation. Certifications may vary depending on country of origin.

Remote 1010, 1410 series ice machine